

Dosing technology

Dosing system

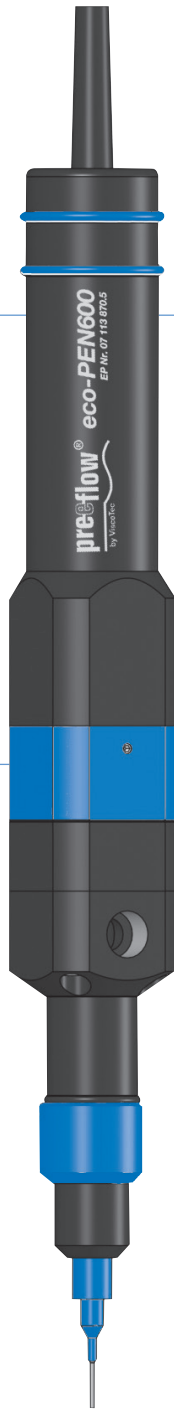

preeflow® *eco-PEN600*
by ViscoTec

DESCRIPTION

The new and innovative precision-volume-dispenser eco-PEN600 made by ViscoTec offers a wide range of applications for low to medium-viscosity dispensing.

THEORY OF FUNCTION

preeflow® eco-PEN is a rotating and perfectly pressure-tight displacement system. Self-sealing rotor/stator design. Conveyance action by medium displacement in the stator through controlled rotor rotation. Safe conveyance without any modification of the medium. With its suck back option, preeflow® ensures clean and controlled material or medium cut-off while preventing post-dripping effects.

APPLICATION

On-the-dot dosage with maximum volumetric precision – dot-and-bead application with application speeds adaptable to track speeds – joint sealing technology.

RANGE OF USES

- Fats
- Colours
- Sealing compounds
- Adhesives
- Oils
- Silicones
- Abrasive media

TECHNICAL FEATURES

- Genuine volumetric dosing
- Viscosity-independent dosing
- Primary pressure-autonomous dosing
- Pressure-tight without valve
- Suck back effect
- Easy to clean
- Controllable dosing flow
- Range of dosing pressures 16 - 20 bar

Self-levelling fluid,
low-viscosity medium

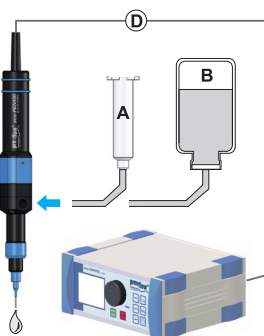

Non-self levelling fluids, medium to high-viscosity medium

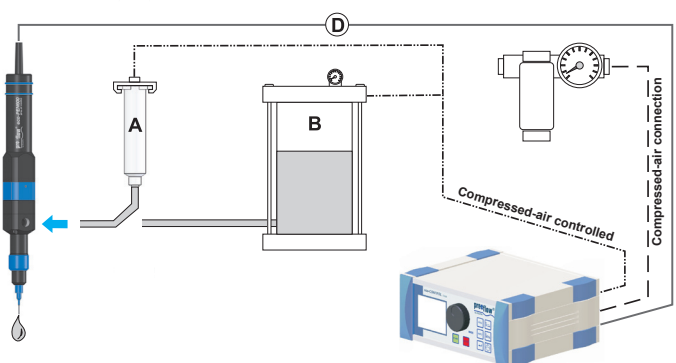

preeflow[®] eco-PEN600

by ViscoTec

Fig.: Side view

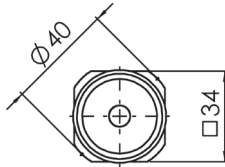
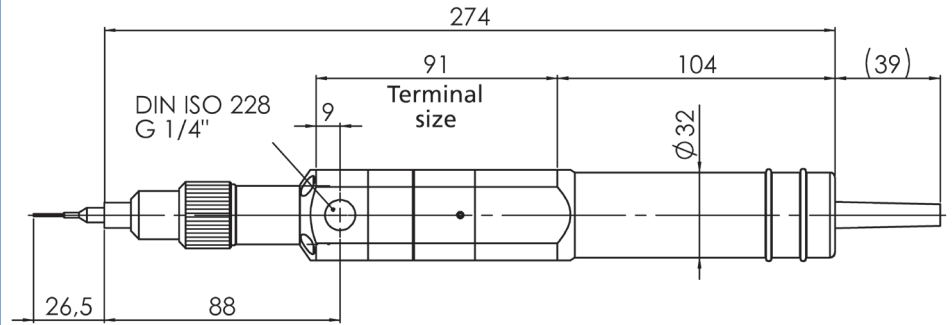
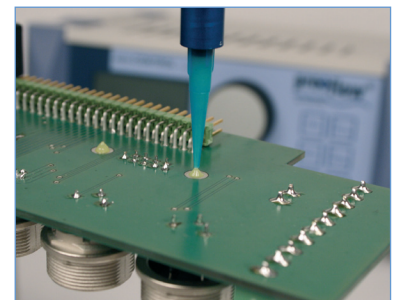

Fig.: Front view



TECHNICAL DATA

Dimensions:	Length 274 mm, □ 34x34 mm, ø 40 mm
Weight:	approx. 750 gram
Material infeed:	1/4" cylindrical whitworth pipe thread DIN/ISO 228
Material outfeed:	Luer lock with O ring, patented
Min. operating pressure:	0 bar, self-levelling-fluid
Max. operating pressure:	0 to 6 bar input pressure, non-self-levelling-fluid
Max. dosing pressure:	16 to 20 bar
Intrinsic tightness ⁽¹⁾ :	approx. 2 bar (reference medium approx. 10mPas at 20°C)
Parts in contact with the media:	HD-POM / stainless steel
Seals:	High-molecular PE, VisChem
Static seals:	Viton O ring (medium) NBR (dust)
Motor:	18 - 24 V DC, incremental encoder, planetary gears
Operating conditions:	+10°C to +40°C, air pressure 1 bar
Medium temperature:	+10°C to +40°C
Storage environment:	dry & dust-free, -10°C - +40°C
Approx. dosing volume per revolution:	0.14 millilitres per revolution
Accuracy of dosing ⁽²⁾ :	± 1%
Repeat accuracy:	> 99%
Min. dosing quantity:	0.004 millilitres
Volume flow ⁽³⁾ :	1.4 to 16.0 millilitres per minute



⁽¹⁾ Max. dosing pressure and intrinsic tightness will decrease in direct proportion to a decrease in viscosity and increase in direct proportion to an increase in viscosity. Consultation with the manufacturer recommended.

⁽²⁾ Volumetric dosing as absolute deviation in relation to one dispenser revolution. Depends on the viscosity of the dosing medium.

⁽³⁾ Volume flow depends on viscosity and primary pressure.



ViscoTec Pumpen- und Dosiertechnik GmbH
Geschäftsfeld Komponenten & Geräte

Amperstraße 4 - D-84513 Töging a. Inn
Tel.: +49 (0) 8631 - 393-400
Fax: +49 (0) 8631 - 393-500
info@viscotec.de
www.viscotec.de



info@preeflow.com
www.preeflow.com

Virtueller eco-PEN:
www.preeflow.com/service