

K-System Syringes Industrial, Kit

Double Syringe 2.5ml / 1:1

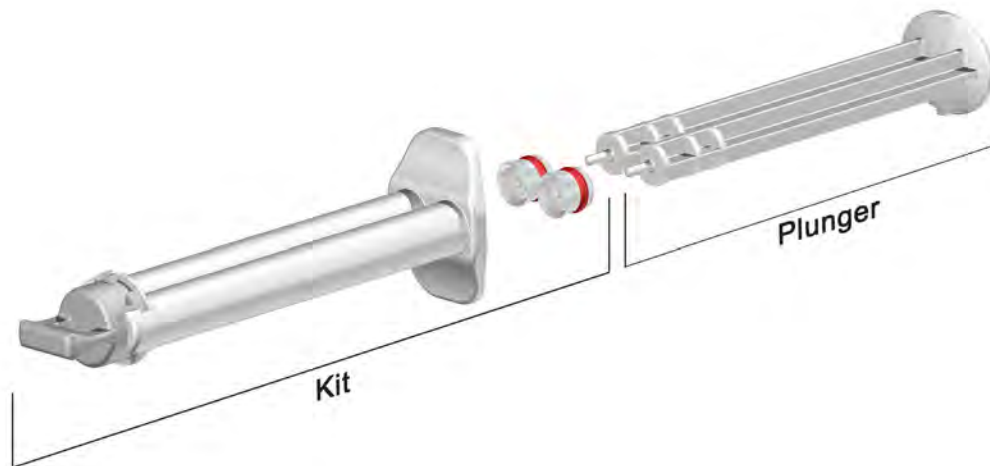

Part number	Article	Description	Units / box
116436	KK 002-01-10-01	Kit 2.5, 1:1, PP white, double syringe, with lip seal pistons, cap dust grey, without plunger	2'000
116437	KK 002-01-10-04	Kit 2.5, 1:1, PP white, double syringe, with pistons with silicon O-ring, cap dust grey, without plunger	2'000
103128	PLH 002-01-45	Plunger, 2.5 ml, 1:1, white	2'000

Headquarters

Sulzer Mixpac Ltd
 phone +41 81 772 20 00
 fax +41 81 772 20 01
 mixpac@sulzer.com
 www.sulzerchemtech.com

USA, South America, Canada and Mexico

Sulzer Mixpac USA Inc.
 phone +1 603 893 27 27
 fax +1 603 893 37 37
 info@SulzerMixpacUSA.com
 www.sulzerchemtech.com

UK and Ireland

Sulzer Mixpac UK
 phone +44 1536 31 29 90
 fax +44 1536 31 29 85
 mixpac@sulzer.com
 www.sulzerchemtech.com

Asia Pacific

Sulzer Mixpac China
 phone +86 21 6430 68 68
 fax +86 21 6430 66 88
 mixpac@sulzer.com
 www.sulzerchemtech.com

K-System Syringes Industrial, Kit

Double Syringe 3ml / 1:1



Part number	Article	Description	Units / pallet
301634	KK 003-01-10-01	Kit 3, 1:1, PP translucide/translucide double syringe, with plunger and mixer	36'000

Headquarters

Sulzer Mixpac Ltd
phone +41 81 772 20 00
fax +41 81 772 20 01
mixpac@sulzer.com
www.sulzerchemtech.com

**USA, South America,
Canada and Mexico**

Sulzer Mixpac USA Inc.
phone +1 603 893 27 27
fax +1 603 893 37 37
info@SulzerMixpacUSA.com
www.sulzerchemtech.com

UK and Ireland

Sulzer Mixpac UK
phone +44 1536 31 29 90
fax +44 1536 31 29 85
mixpac@sulzer.com
www.sulzerchemtech.com

Asia Pacific

Sulzer Mixpac China
phone +86 21 6430 68 68
fax +86 21 6430 66 88
mixpac@sulzer.com
www.sulzerchemtech.com

K-System Syringes Industrial, Kit

Double Syringe 5ml / 1:1

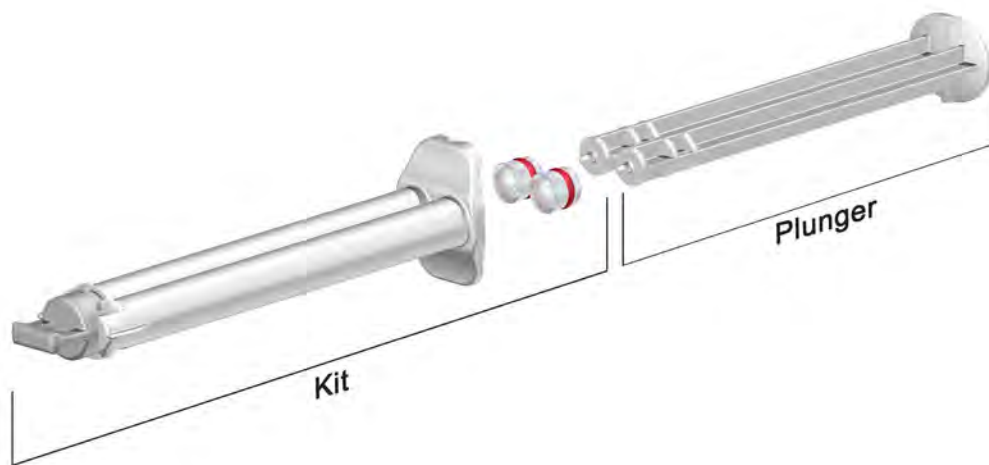

Part number	Article	Description	Units / box
116438	KK 005-01-10-01	Kit 5, 1:1, PP white, double syringe, with lip seal pistons, cap dust grey, without plunger	1'500
116439	KK 005-01-10-04	Kit 5, 1:1, PP white, double syringe, with pistons with silicon O-ring, cap dust grey, without plunger	1'500
113403	PLH X05-01-45	Plunger, 5 ml, 1:1, white	2'000

Headquarters

Sulzer Mixpac Ltd
 phone +41 81 772 20 00
 fax +41 81 772 20 01
 mixpac@sulzer.com
 www.sulzerchemtech.com

USA, South America, Canada and Mexico

Sulzer Mixpac USA Inc.
 phone +1 603 893 27 27
 fax +1 603 893 37 37
 info@SulzerMixpacUSA.com
 www.sulzerchemtech.com

UK and Ireland

Sulzer Mixpac UK
 phone +44 1536 31 29 90
 fax +44 1536 31 29 85
 mixpac@sulzer.com
 www.sulzerchemtech.com

Asia Pacific

Sulzer Mixpac China
 phone +86 21 6430 68 68
 fax +86 21 6430 66 88
 mixpac@sulzer.com
 www.sulzerchemtech.com

K-System Syringes Industrial, Kit

Double Syringe 10ml / 1:1

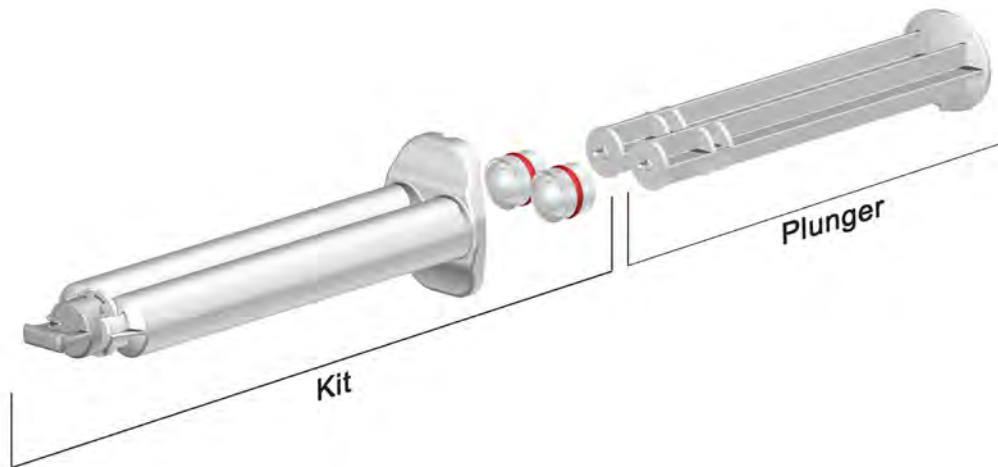

Part number	Article	Description	Units / box
116440	KK 010-01-10-01	Kit 10, 1:1, PP white, double syringe, with lip seal pistons, cap dust grey, without plunger	500
116441	KK 010-01-10-04	Kit 10, 1:1, PP white, double syringe, with pistons with silicon O-ring, cap dust grey, without plunger	500
113401	PLH X10-01-45	Plunger, 10 ml, 1:1, white	1'000

Headquarters

Sulzer Mixpac Ltd
 phone +41 81 772 20 00
 fax +41 81 772 20 01
 mixpac@sulzer.com
 www.sulzerchemtech.com

USA, South America, Canada and Mexico

Sulzer Mixpac USA Inc.
 phone +1 603 893 27 27
 fax +1 603 893 37 37
 info@SulzerMixpacUSA.com
 www.sulzerchemtech.com

UK and Ireland

Sulzer Mixpac UK
 phone +44 1536 31 29 90
 fax +44 1536 31 29 85
 mixpac@sulzer.com
 www.sulzerchemtech.com

Asia Pacific

Sulzer Mixpac China
 phone +86 21 6430 68 68
 fax +86 21 6430 66 88
 mixpac@sulzer.com
 www.sulzerchemtech.com

K-System Syringes Industrial, Kit

Double Syringe 10ml / 10:1

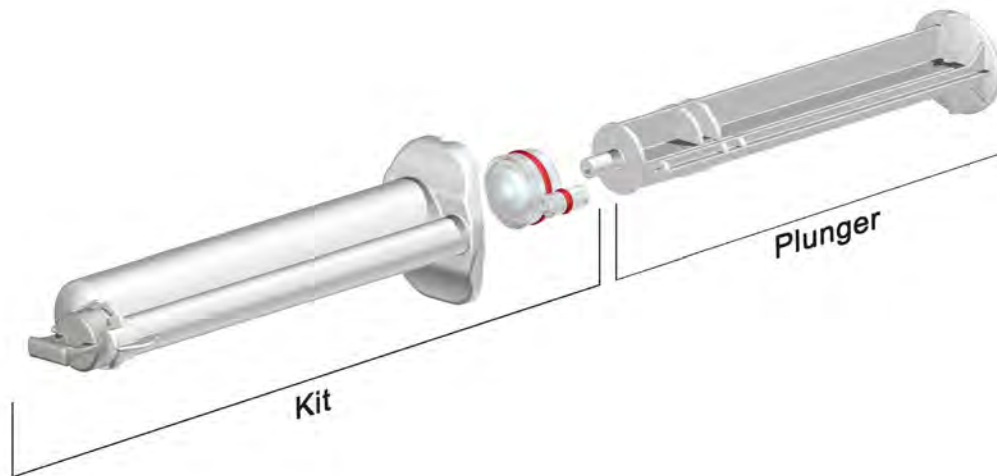

Part number	Article	Description	Units / box
116442	KK 010-10-10-01	Kit 10, 10:1, PP white, double syringe, with lip seal pistons, cap dust grey, without plunger	500
116435	KK 010-10-10-04	Kit 10, 10:1, PP white, double syringe, with pistons with silicon O-ring, cap dust grey, without plunger	500
116571	KK 010-10-20-01	Kit 10, 10:1, PBT white, double syringe, with lip seal pistons, cap dust grey, without plunger	500
113371	PLH X10-10-45	Plunger, 10 ml, 10:1, white	1'000

Headquarters

Sulzer Mixpac Ltd
 phone +41 81 772 20 00
 fax +41 81 772 20 01
 mixpac@sulzer.com
 www.sulzerchemtech.com

USA, South America, Canada and Mexico

Sulzer Mixpac USA Inc.
 phone +1 603 893 27 27
 fax +1 603 893 37 37
 info@SulzerMixpacUSA.com
 www.sulzerchemtech.com

UK and Ireland

Sulzer Mixpac UK
 phone +44 1536 31 29 90
 fax +44 1536 31 29 85
 mixpac@sulzer.com
 www.sulzerchemtech.com

Asia Pacific

Sulzer Mixpac China
 phone +86 21 6430 68 68
 fax +86 21 6430 66 88
 mixpac@sulzer.com
 www.sulzerchemtech.com

K-System Industrial

Mixer Helix for System K, 1:1/2:1

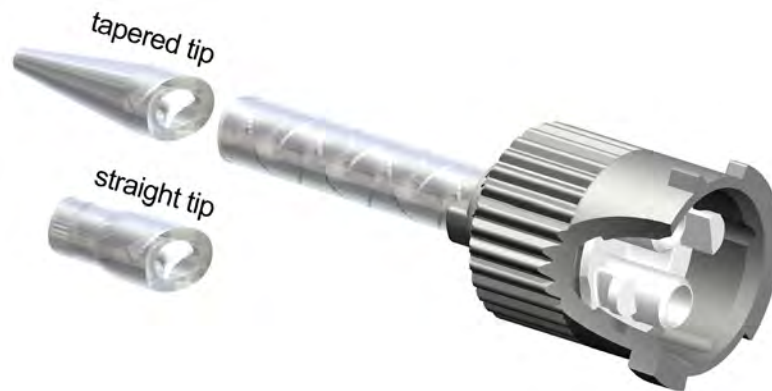

Part number	Article	Description	Elements	Ø (mm)	L (mm)	Vol. (ml)	Units / box
114252	MKH 02-08D	Mixer helix, 1:1/2:1 light grey, white elements, straight tip	8	2.5	33.4	0.14	9'000
114246	MKH 02-08S	Mixer helix, 1:1/2:1 light grey, white elements, tapered tip	8	2.5	39.7	0.19	9'000
114253	MKH 02-12D	Mixer helix, 1:1/2:1 light grey, white elements, straight tip	12	2.5	46.2	0.23	8'000
114249	MKH 02-12S	Mixer helix, 1:1/2:1 light grey, white elements, tapered tip	12	2.5	49.7	0.23	8'000
115686	MKH 02-16S	Mixer helix, 1:1/2:1, light grey, white elements, tapered tip	16	2.5	59.7	0.27	7'000
114254	MKH 03-12D	Mixer helix, 1:1/2:1 dust grey, white elements, straight tip	12	3.2	56.0	0.39	6'000
114250	MKH 03-12S	Mixer helix, 1:1/2:1 dust grey, white elements, tapered tip	12	3.2	61.0	0.39	6'000
114251	MKH 03-16S	Mixer helix, 1:1/2:1 dust grey, white elements, tapered tip	16	3.2	74.0	0.49	4'000

Headquarters

Sulzer Mixpac Ltd
phone +41 81 772 20 00
fax +41 81 772 20 01
mixpac@sulzer.com
www.sulzerchemtech.com

USA, South America, Canada and Mexico

Sulzer Mixpac USA Inc.
phone +1 603 893 27 27
fax +1 603 893 37 37
info@SulzerMixpacUSA.com
www.sulzerchemtech.com

UK and Ireland

Sulzer Mixpac UK
phone +44 1536 31 29 90
fax +44 1536 31 29 85
mixpac@sulzer.com
www.sulzerchemtech.com

Asia Pacific

Sulzer Mixpac China
phone +86 21 6430 68 68
fax +86 21 6430 66 88
mixpac@sulzer.com
www.sulzerchemtech.com

K-System Industrial

Mixer Helix for System K, 4:1/10:1

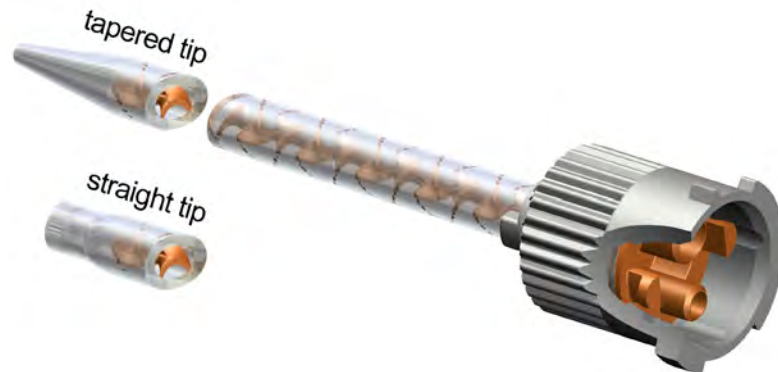

Part number	Article	Description	Elements	Ø (mm)	L (mm)	Vol. (ml)	Units / box
114260	MKHX 02-08D	Mixer helix, 4:1/10:1 dust grey, orange elements, straight tip	8	2.5	36.2	0.19	9'000
114255	MKHX 02-08S	Mixer helix, 4:1/10:1 light grey, orange elements, tapered tip	8	2.5	39.7	0.19	9'000
114261	MKHX 02-12D	Mixer helix, 4:1/10:1 dust grey, orange elements, straight tip	12	2.5	46.2	0.23	8'000
114256	MKHX 02-12S	Mixer helix, 4:1/10:1 light grey, orange elements, tapered tip	12	2.5	49.7	0.23	8'000
114257	MKHX 02-16S	Mixer helix, 4:1/10:1 light grey, orange elements, tapered tip	16	2.5	59.7	0.27	7'000
114262	MKHX 03-12D	Mixer helix, 4:1/10:1 dust grey, orange elements, straight tip	12	3.2	56.0	0.39	6'000
114258	MKHX 03-12S	Mixer helix, 4:1/10:1 light grey, orange elements, tapered tip	12	3.2	61.0	0.39	6'000
114259	MKHX 03-16S	Mixer helix, 4:1/10:1 light grey, orange elements, tapered tip	16	3.2	74.0	0.49	4'000

Headquarters

Sulzer Mixpac Ltd
phone +41 81 772 20 00
fax +41 81 772 20 01
mixpac@sulzer.com
www.sulzerchemtech.com

USA, South America, Canada and Mexico

Sulzer Mixpac USA Inc.
phone +1 603 893 27 27
fax +1 603 893 37 37
info@SulzerMixpacUSA.com
www.sulzerchemtech.com

UK and Ireland

Sulzer Mixpac UK
phone +44 1536 31 29 90
fax +44 1536 31 29 85
mixpac@sulzer.com
www.sulzerchemtech.com

Asia Pacific

Sulzer Mixpac China
phone +86 21 6430 68 68
fax +86 21 6430 66 88
mixpac@sulzer.com
www.sulzerchemtech.com